

## WHY SHOULD YOUR CUSTOMER PURCHASE A PLANTRONICS HEADSET?

Today, communications – via traditional phones, mobiles or Internet telephony – are at the centre of virtually every business activity. Businesses and organisations need trusted partners and suppliers for their hardware solutions that support all their business activities.

Plantronics offers:

- An unmatched track record
- Proven acoustic excellence
- Exceptional product range
- Industry leading service and support.

As the worldwide market leader and partner of major corporations such as Alcatel-Lucent, we spend millions of dollars every year researching and developing sound solutions that anticipate and respond to all the business needs of your customers.

### Why use a headset?

Research shows that overall productivity could be increased by up to 43%\* simply by using a telephone headset, rather than a traditional telephone handset.

Most of all, headsets empower the individual user by providing five key advantages:

- **Hands free Advantage:** No more juggling with your phone handset – type and talk as well as collecting that important document from the printer – complete office freedom
- **Sound Advantage:** More clarity – you can hear better and be heard. It saves time and reduces stress
- **Ergonomic Advantage:** No more cradling a handset between your shoulder and neck – you can be more comfortable and avoid strain, back and neck pain
- **Mobility Advantage:** No more being tied to your phone – you're free to move around as you talk and you will miss less calls and stop diversion to voicemail – improve customers satisfaction
- **Efficiency Advantage:** Be able to multi-task whilst managing your daily activities – your phone, mobile and PC all enable you to become more productive.

### Complete peace of mind with industry leading warranties

All our call centre and office products come with a standard 2 year warranty with the option, at the time of purchase, to extend to a third year warranty (corded call centre and office headsets, amplifiers and adapters only).

### More information

Contact us on the telephone numbers overleaf for more information or visit [www.plantronics.com](http://www.plantronics.com). To ensure all our channel partners have access to the most current product information and sales tools, visit [www.plantronics.com](http://www.plantronics.com)

### Additional Sales opportunities

Plantronics offer a wide range of accessories for our headset range. From handset lifter and amplifiers to coloured voice tubes and gel ear cushions. Always ensuring the best headset wearing experience.

## MAKE THE RIGHT CHOICE

TCO'07 Headsets is a global labelling certification for Headsets. It demonstrates that Plantronics products have passed independent research and testing across users, manufacturers, researchers and industry experts.



TCO approved headsets have fulfilled the following criteria:

- |  |   |
|--|---|
| <ul style="list-style-type: none"> <li>✓ <b>Ergonomics</b> <ul style="list-style-type: none"> <li>• Built-in acoustic limit protection</li> <li>• Easily adjustable with flexible wearing styles</li> <li>• Replaceable parts for better hygiene</li> </ul> </li> <li>✓ <b>Emissions</b> <ul style="list-style-type: none"> <li>• Low SAR radiation (below 0.04 W/kg)</li> <li>• Low electric/magnetic fields</li> </ul> </li> </ul> | <ul style="list-style-type: none"> <li>✓ <b>Ecology</b> <ul style="list-style-type: none"> <li>• ISO 14001 certified manufacturing</li> <li>• Minimisation of environmentally hazardous substances</li> </ul> </li> <li>✓ <b>Energy</b> <ul style="list-style-type: none"> <li>• Optimised energy usage and efficiency</li> </ul> </li> </ul> |
|--|---|

Plantronics has a 100% pass rate and more TCO certifications than any other headset manufacturer.

\* Research by HB Maynard & Co.

## WIRELESS HEADSET INSTALLATION INFORMATION:

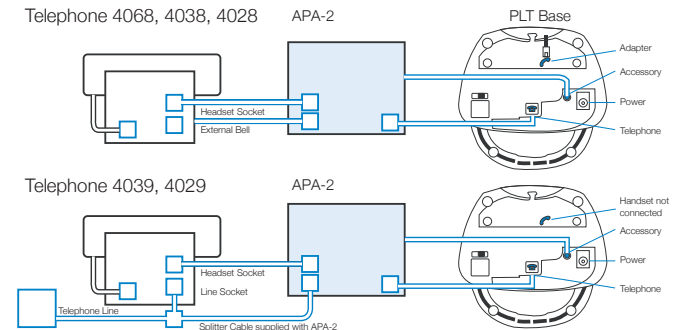

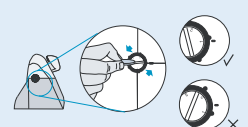
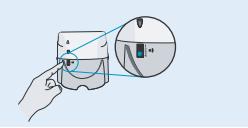
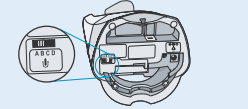
Headset set up information	Diagrams
Set rotary switch to 1	
Set rear slide switch to 3	
Set bottom slide switch to B	

Please see the user guide for complete set up information.

# COMPLETE YOUR ALCATEL-LUCENT PHONE SOLUTION WITH A PLANTRONICS HEADSET



WHICH ALCATEL-LUCENT PHONE?

DESKPHONE



IP Touch 8 series  
4068\*, 4038\*,  
4028\*, 4018,  
4008



9 series TDM  
4039\*, 4029\*,  
4019



Reflexes™ \*\*\*  
Advanced,  
Premium,  
Easy

SOFTPHONE



My Phone/  
4980  
PIMphony

## WIRELESS SOLUTIONS FOR DESKPHONE



**PLANTRONICS VOYAGER™ 510S**  
Office and Mobile phone usage  
One headset to share seamlessly between the office phone and Bluetooth® mobile phone or smart phone.

**72272-04** Noise-Cancelling with WindSmart®



**CS60X™**  
Choice of wearing styles  
Cost-effective wireless headset with great range and sound quality and a choice of wearing styles.

**38516-01** Noise-Cancelling with APA-2

For use with IP Touch 8 and 9 series\* only



**CS70N™**  
Stylish and discreet  
Combining the excellent sound quality and range of DECT™ with the design edge of a mobile headset.

**39448-01** Noise-Cancelling  
**39449-01** Noise-Cancelling with HL10



**SUPRAPLUS® WIRELESS**  
Over-the-head wearing comfort  
Comfort and great sound quality – with the option of binaural style for noisy environments.

**39986-01** Monaural Noise-Cancelling  
**39261-01** Binaural Noise-Cancelling  
**39987-01** Monaural Noise-Cancelling with HL10  
**39263-01** Binaural Noise-Cancelling with HL10

## ELECTRONIC HOOK SWITCH SOLUTIONS

Answer calls at the push of a button while away from your desk

**38516-01\*** Requires CS60X + APA2 Bundle  
**36390-11\*\*** Requires HL10



HL10 = Handset lifter

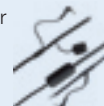

APA-2

## CORDED SOLUTIONS FOR DESKPHONE & SOFTPHONE



**DUOSET®**  
Cost effective headset with adjustable headband provides a flexible choice for Office workers.

**34623-21** Convertible Voice Tube  
**34625-21** Convertible Noise-Cancelling



**SUPRAPLUS®**  
A winning combination of great audio performance and reliability.

**36828-01** Monaural Voice Tube  
**36832-01** Monaural Noise-Cancelling  
**36830-01** Binaural Voice Tube  
**36834-01** Binaural Noise-Cancelling



**ENCOREPRO™**  
Designed for performance, built to last Uncompromising style, comfort, reliability and audio quality.

**78712-02** Monaural Noise-Cancelling  
**78714-02** Binaural Noise-Cancelling

## REQUIRED DESKPHONE CONNECTORS



U10P

**CONNECTOR CABLES**  
Connect your headset to your phone

**38324-01** IP Touch Cable 4068/4038/4028/4039/4029  
**34286-03** BiWay + **32145-01** U10P cable for 4008/4018/4019/Reflexes

OR



**AUDIO PROCESSOR VISTA™ M12**

Audio Processor for superior sound quality and acoustic protection, including volume and mute controls.

**33413-11** Audio Processor

## REQUIRED SOFTPHONE CONNECTORS



**DA40™ AUDIO PROCESSOR**  
Connect your headset to your PC USB port.

OR

**DA45™ AUDIO PROCESSOR**  
Connect your headset to your PC USB port with enhanced sound quality.

**71800-02**  
USB Audio Processor

**77559-02**  
USB Audio Processor

## WIRELESS SOLUTIONS FOR SOFTPHONE



**PLANTRONICS VOYAGER 510™ USB**  
Office and Mobile phone usage  
One headset to cover both mobile phone and VoIP use.

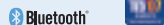

**72270-45** with WindSmart



**CS60™ USB**  
Choice of wearing styles  
Wireless headset with great range and sound quality and a choice of wearing style ideal for IP telephony applications.

**36947-01** Noise-Cancelling

## CORDED SOLUTIONS FOR MOBILE REFLEXES

Mobile Reflexes 400, 200, 100



**DUOSET®**  
Cost effective headset with adjustable headband provides a flexible choice for Office workers.

**37054-01**  
Monaural Noise-Cancelling